

D&RHenderson

Independent | Sustainable | Competitive

Floorboard

installation guidelines

**Now With Five*
Months Warranty**

**AUSTRALIAN MADE
AUSTRALIAN OWNED**

Orange Tongue

Burgundy Tongue

Navy Tongue

D&R Henderson Floorboard

D&R Henderson have been manufacturing all purpose tongue and grooved particleboard flooring since 1987. Unlike many particleboards, our Floorboard products have a wax solution incorporated into the resin mix, allowing for greater edge protection if sheets are cut.

D&R Henderson **Floorboard** meets all the requirements of the Australian standard AS/NZS 1860.1 and is suitable for domestic and commercial installations. There are number of thicknesses available to cover your building requirements.

Orange Tongue

19mm for 450mm joists

Burgundy Tongue

22mm for 600mm joists

Navy Tongue

25mm for 450mm joists*

**Dependent on nature of use and floor loading*

Floorboard Product Range

Orange Tongue (19mm)

A high quality interior all purpose flooring for use in domestic and some commercial buildings, designed for both platform and fitted flooring construction methods. Also available as Termite Treated

Burgundy Tongue (22mm)

As above for Orange tongue but is 22mm thick to allow for maximum joist centre span of 600mm. Also available as Termite Treated.

Navy Tongue (25mm)

A heavy duty 25mm thick floorboard specifically for residential, commercial, industrial and institutional buildings that are subject to increased floor loads. Refer to Australian Standards for floor loading details. (In some circumstances alternative fixing methods to those in this publication may be necessary).

H2 Termite Treated Floorboard (19mm & 22mm)

As part of its range D&R Henderson also provide termite treated flooring which can be used in conjunction with other preventative measures to minimise termite attack. The board is impregnated with a synthetic pyrethrin during the manufacturing process which significantly improves its termite resistance properties. The registered brand is 272.20 H2 level.

Site Storage

Although **Floorboard** is resistant to moisture, packs must be protected from the weather until the particleboard is installed. Packs should be stored off the ground with supports about 600mm apart. Packs need to be protected on the top and sides with waterproof material such as plastic sheeting. (The covering should allow for air circulation during the storage period).

Effects of Moisture and Wetting

Floorboard is a wood-based product and will react to changes in moisture and direct wetting by expanding or shrinking in the length and width and swelling or shrinking in the thickness. Under unduly wet conditions, the open groove will close significantly and will open when dry to perhaps a wider groove than the original cut-out. For optimum performance

it is best to keep the **Floorboard** as dry as possible. Once it is laid **Floorboard** may be exposed to the weather for up to five months in compliance with the requirements of AS/NZS 1860.1 for particleboard flooring. If water ponding occurs then drain holes can be provided where needed by drilling holes of 3mm maximum in diameter with no less than 1m spacing between them.

Floorboard, like other wood-based products and many other building materials, will respond to changes in relative humidity or the surrounding air. Board dimensions are closely related to moisture content. The ex-factory moisture content is about 8.5% with a usual range of $\pm 1\%$. The highest potential for moisture movement exists when Particleboard Flooring is exposed to the weather as platform construction. Sheets which have been left exposed on a building site should be dried out before installation to avoid shrinkage gaps later.

Sheet Layout and Nailing

Sheets are laid with the long length across floor joists with ends butted over a joist. Sheet end joists are staggered as shown opposite. Set a string line at the ends of joists parallel to the perimeter of the building and at right angles to the joists. Position the first sheet with its tongued edge to the string line. Ensure that information printed on the sheets

is followed to give the correct top surface. The minimum docked sheet length must span at least 3 consecutive joists. See AS/NZS1860.2 Section 9.1



**D&R Henderson
proudly recycles**

Our recycling process is a genuine perpetual "closed loop" recycling method. We utilise various woodwaste, timber offcuts, waste, pallets, crates, particleboard, plywood, and reconstitute this back into particleboard. Traditional preprocessing methods would see this wood waste turned into Bio fuel, landfill, compost or other secondary uses that will still become terminally wasted wood resource.

In any one month the amount of **Post Consumer wood waste** delivered to Benalla for cleaning can exceed 714 tonne.

For many years we have held a **deep commitment to maintaining manufacturing processes** which are both efficient and environmentally friendly. The investments that we have made in the last 3 years in plant equipment and logistics will enable us to continue to pioneer technologies in this area, honouring our commitment to a sustainable future.

Installation Guidelines

FIXING – In accordance with Local Council and State Regulations – Minimum requirements as per AS/NZS1860.2 Section 10.

Floorboard should be fixed with construction-grade adhesive and mechanical fasteners in accordance with the Adhesive Manufacturer's instructions. A bead of continuous adhesive should be applied from the cartridge applicator to joists before positioning **Floorboard** sheets. The bead should be 5-6mm across and must not be laid too far ahead as it may cure quickly. The adhesive bead must not be allowed to dry and become hard on the surface. The open time available will depend on weather conditions which may restrict advance adhesive application to the amount required for one sheet only.

An extra bead along the tongue should be applied before sheets are pressed together which should ensure a squeak-free floor system and increased protection against weather elements once laid. Any excess glue squeezed out should be cleaned off. When sheets are cut on site, the cut edge should be sealed with adhesive.

NAILING – Select an appropriate nail for the thickness of **Floorboard** being used. Nails should be spaced at 150mm centres along sheet ends and at 300mm centres over the rest of the sheet. Nails should not be placed closer than 25mm to the long (grooved) edges and 10mm to the short butt joined edges (refer below).

Nails may be applied by hand or by nailing gun. With gun nailing care should be taken to adjust air pressure for softwood or hardwood joists, so that nails do not penetrate the surface by more than 1mm. Do not allow nails to pull the board to the top of the joists – the fixer should use his body weight to ensure that the underside of the sheet is in firm contact with the joist before firing the nail.

Use minimum 50 x 2.8mm galvanised nails for hardwood or Cypress pine joists and minimum 65mm x 2.8mm galvanised nails for softwood joists. Nails may have Bullet, Jolt, Flat or Countersunk heads, However, Bullet or Jolt head nails should be skewed to improve holding power. Nails should be driven flush initially and not punched until immediately prior to sanding. Power driven nails should be minimum 55mm x 2.5mm Tee Head or Finished Head for all timber joists. Use only galvanised or rust-resistant nails.

METAL JOISTS – Construction adhesive and extended point self-tapping screws (e.g. No 10 x 45mm CSK from W.A. Deuscher or similar) are recommended. Screw spacing is the same as specified for nailing. Use in accordance with manufacturer's instructions.

CONSTRUCTION PLATFORM FLOORING – Methods described generally apply to Platform Construction (refer below) or AS/NZS1860.2 Section 4 for further details. Although an exposure period of 5 months maximum is permitted, efforts should be made to protect **Floorboard** from excessive exposure. Any ponded water should be swept off as soon as possible. Drain holes can be provided by drilling holes of 3mm maximum in diameter, at not less than 1m spacing, through the floor where water ponding occurs. Roof cover should be provided as soon as possible. Excessive and differential drying can be caused by the hot Australian sun. This may result in cupping which could, in extreme cases, cause nail pull-out or pull through of nail heads. In very severe cases, shading may be needed, or alternatively water should be sprayed onto the **Floorboard** surface to recondition sheets back to uniform moisture content.

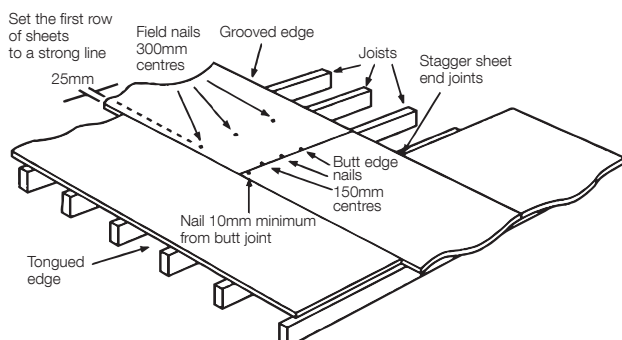

In general, attempts should be made to keep the exposure time to a minimum. Damage may be caused by other tradesmen and attention is needed to avoid:

- wet trades using the floor as a mixing table
- excessive spillages of paint, plaster, concrete, etc.
- stacking of heavy materials such as bricks, cement-bags, sand.

FITTED FLOORING – Fitted floors are those installed after internal walls are constructed and usually after the roof and wall claddings are fixed. Fixing

is basically as described. An expansion gap of 10mm must be left around all walls, this gap will later be covered by skirting boards (refer below).

WET AREAS – For use in wet areas fixing must be in accordance with local council and state regulations with minimum requirements as per AS/NZS3740. The board must be covered with an approved impervious membrane and flashing must be carried out in strict accordance to local and state regulations and in accordance with the membrane manufacturer's instructions. **Floorboard** should be laid on seasoned gauged bearers and joists. A moulded shower base or prefabricated shower tray should be used. Under floor ventilation must comply with local council regulations.

FINISHING – Depending upon the degree and duration of platform exposure, it may be necessary to sand **Floorboard** at the completion of construction to maintain a clean smooth surface. Sanding should be carried out in accordance with AS/NZS1860.2 Section 12.

TILES (Ceramic, Slate, Quarry, Marble or similar) **Vinyl and related flooring overlay products** – It is necessary for these products to be laid onto a suitably prepared underlay surface to avoid cracking around the joints of the sheets of particleboard, which are a wood product and are subject to expansion and contraction as are all wood products used in construction. Typical underlays for general living areas, kitchens, hallways and entrance foyers, include fibre cement sheeting or flexible levelling compounds. It is important that the supplier's recommendations be followed in relation to the selection and application of primers, underlay, adhesives and ceramic floor tiles. Expansion joints should be provided between tiles at approximately five metre intervals and at the perimeter of large floors. Failure to follow this procedure could cause varying degrees of cracking in both the tiles and joints.

SAFETY RECOMMENDATIONS – The normal health and safety precautions should be taken when working with wood panel products. Machine tools should be fitted with dust extractors. If dust levels exceed the National Occupational Health & Safety Commission's Standards, the wearing

of a dust mask (AS/NZS 1715 and AS/NZS 1716) and safety glasses (AS/NZS 1337) is recommended. Storage and work areas should be adequately ventilated. Material Safety Data Sheets for particleboard is available on request from any branch of D&R Henderson.

Our recycling process is a genuine perpetual "closed loop" recycling method. We utilise various woodwaste, timber offcuts, waste, pallets, crates, particleboard, plywood, and reconstitute this back into particleboard. Traditional reprocessing methods would see this wood waste turned into Bio fuel, landfill, compost or other secondary uses that will still become a terminally wasted wood resource.

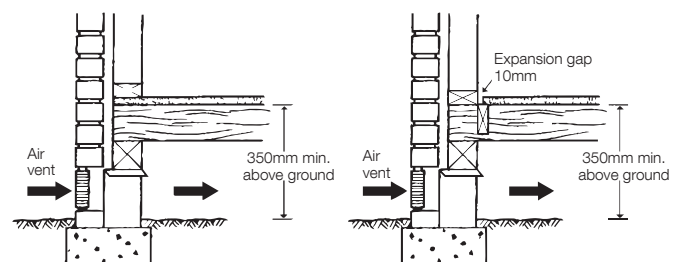

PRODUCT	TYPE	THICKNESS	SHEET SIZE	SHEETS PER PACK	M2 PER PACK	MAX JOIST SPAN
Orange Tongue	Standard	19mm	3600 x 600 3600 x 800 3600 x 900	36	103.6 116.6	450mm
Orange Tongue	H2 Termite Treated	19mm	3600 x 800 3600 x 900	36	103.6 116.6	450mm
Burgundy Tongue	Standard	22mm	3600 x 800 3600 x 900	32	92.2 103.7	600mm
Burgundy Tongue	H2 Termite Treated	22mm	3600 x 800 3600 x 900	32	92.2 103.7	600mm
Navy Tongue	Standard	25mm	3600 x 600	27	58.3	600mm

* Dependent on nature of use and floor loading

Typical Property Values for Class 1 Particleboard Flooring

PROPERTIES	UNITS	19mm	22mm	25mm
Density	KG/m ³	680	700	700
Bending Strength (MOR)	MPa	24	21	24
Bending Stiffness (MOE)	MPa	3500	3250	3750
Internal Bond Strength	KPa	0.7	0.75	0.8
24hr Thickness Swell	%	3	3	2
Thickness Stability	%	11	11	11
Glue Bond Quality	%	12	12	12
Glue Bond Durability	MPa	5.5	5.5	6
Surface Water Absorption	g/m ²	50	50	50

Fire Hazard Indices

(Typical achieved when tested to AS/NZS 1530.3)

INDICIES	RESULT	RANGE
Ignitability	12-13	0-20
Spread of Flame	6-7	0-10
Heat Evolved	7-8	0-10
Smoke Developed	2-3	0-10

Floorboard is manufactured to satisfy the requirements of AS/NZS 1860.1

For further details on fixing Floorboard refer to AS/NZS 1860.2

Head Office

25 Liberty Road
Huntingwood NSW 2148

☎ 02 8118 3600 📠 02 8118 3688

enquiries@drhenderson.com.au

Customer Service Centre

☎ 1300 733 266 📠 1300 733 264

customer.service@drhenderson.com.au

drhenderson.com.au



D&R Henderson - Mansfield Plant
ET AS/NZS 1860.1: Licence No: 003

D&R Henderson

Independent | Sustainable | Competitive